

Dynapac CA5500D

Single drum vibratory rollers

Atlas Copco



Technical data



Masses

Operating mass (incl. ROPS)	40,131 lbs
Operating mass (incl. Cab)	40,400 lbs
Module mass (front/rear)	26,100/14,300 lbs
Max. operating mass	41,000 lbs



Dimensions

Drum width	84 in
------------	-------



Propulsion

Speed range	2-7 mph
Vertical oscillation	±9°
Theor. gradeability	56 %
Tire size (12 ply)	23,1 x 26



Compaction

Static linear load	314 lbs/in
Nominal amplitude (high/low)	0.083/0.031 in
Vibration frequency (high/low amplitude)	1,740/1,800 vpm
Centrifugal force (high/low amplitude)	80,940/33,720 lb



Engine

Fuel tank capacity	72 gal
--------------------	--------



Engine

Manufacturer/Model	Deutz TCD6,1L06 (T4i)
Rated power, ISO 14396	129 kW (173 hp) @ 2,200 rpm



Hydraulic system

Driving	Hydrostatic
Vibration	Hydrostatic
Steering	Hydrostatic
Service brake	Hydrostatic in forward and reverse lever.
Parking/Emergency brake	Failsafe multidisc brake in drum gear box and in rear axle.

Find us locally at www.atlascopco.com

We reserve the right to change specifications without notice. Photos and illustrations do not always show standard versions of machines. The above information is a general description only, all informations are supplied without liability.

rce_ca5500d_us-20140313.135629.pdf 2014-03-13 13:56

Dynapac CA5500D

Single drum vibratory rollers

Atlas Copco

Technical data

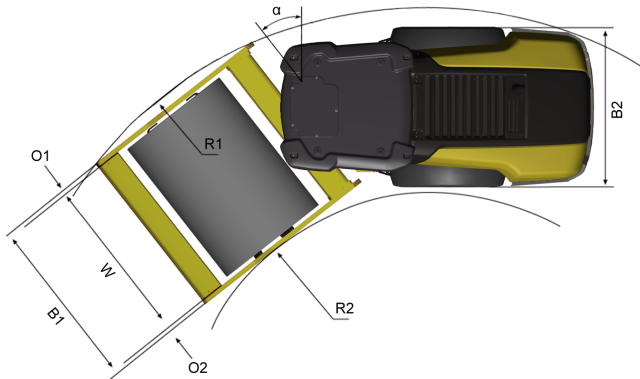
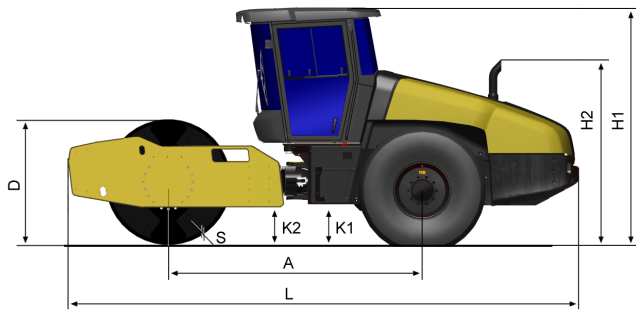

Dimensions	
A. Wheelbase	122 in
B1. Width, front	92 in
B2. Width, rear	84 in
D. Drum diameter	61 in
H1. Height, with ROPS/cab	114 in
H2. Height, w/o ROPS/cab	84 in
K1. Ground clearance	18 in
K2. Curb clearance	18 in
L. Length	246 in
O1. Overhang, right	4 in
O2. Overhang, left	4 in
R1. Turning radius, outside	19 ft
R2. Turning radius, inside	11 ft
S. Drum shell thickness	1.89 in
W. Drum width	84 in
α. Steering angle	±38°



Standard equipment

- 24V outlet socket, operator's platform
- Automatic vibration control
- Back up alarm
- Brake release
- Cross Mounted Engine
- Combi cooler with Hydraulically driven fan
- Display: Engine temp, Fuel level, Hydr. temp, Speedometer, Tachometer, Voltage
- Dual speed drum drive motor
- Emergency stop
- Filler cap inside lockable hood
- Hydraulic checkpoints
- Parking brake
- Shock mounted platform
- Steering wheel, adjustable
- Suspension seat
- Storage Compartment
- Vandal cover
- Warning lights: Air cleaner, Brake, Clogged hyd. fluid filter, Engine oil pressure/temp, Hyd oil temp, Low charge, Low fuel
- 1m X 1m Visibility
- Zero spill oil & coolant change

Find us locally at www.atlascopco.com

We reserve the right to change specifications without notice. Photos and illustrations do not always show standard versions of machines. The above information is a general description only, all informations are supplied without liability.

rce_ca5500d_us-20140313.135629.pdf 2014-03-13 13:56