

Dynapac CA3500D

Single drum vibratory rollers

Atlas Copco



Technical data



Masses

Operating mass (incl. ROPS)	26,200 lbs
Operating mass (incl. Cab)	26,676 lbs
Module mass (front/rear)	16,800 lbs/9,900 lbs
Max. operating mass	30,400 lbs



Dimensions

Drum width	84 in
------------	-------



Propulsion

Speed range	2-7 (mph)
Tire size (8 ply)	23,1 x 26 AW
Theor. gradeability	55 %
Vertical oscillation	±9°



Compaction

Static linear load	201.57 lbs/in
Nominal amplitude (high/low)	0.075 in/0.035 in
Vibration frequency (high/low amplitude)	1,860 vpm/2,040 vpm
Centrifugal force (high/low amplitude)	62,950 lb/38,220 lb



Engine

Manufacturer/Model	Cummins QSB 4.5 (IIIB/4i)
Type	Water cooled turbo Diesel
Fuel tank capacity	72 gal
Rated power, SAE J1995	119 kW (162 hp) @ 2,200 rpm



Hydraulic system

Driving	Hydrostatic
Vibration	Hydrostatic
Steering	Hydrostatic
Service brake	Hydrostatic in forward and reverse lever.
Parking/Emergency brake	Failsafe multidisc brake in drum gear box and in rear axle.

Find us locally at www.atlascopco.com

We reserve the right to change specifications without notice. Photos and illustrations do not always show standard versions of machines. The above information is a general description only, all informations are supplied without liability.

rce_ca3500d_us-20151207.160812.pdf 2015-12-07 16:08

Dynapac CA3500D

Single drum vibratory rollers

Atlas Copco

Technical data

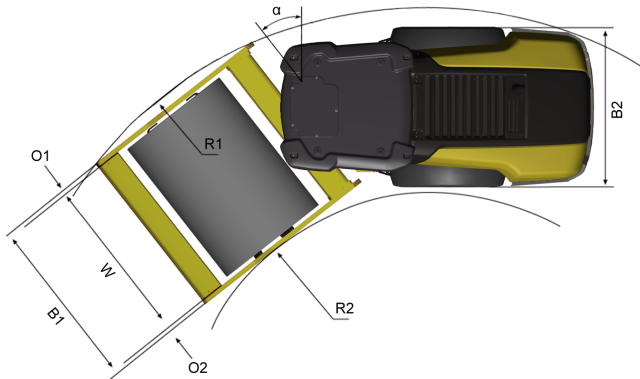
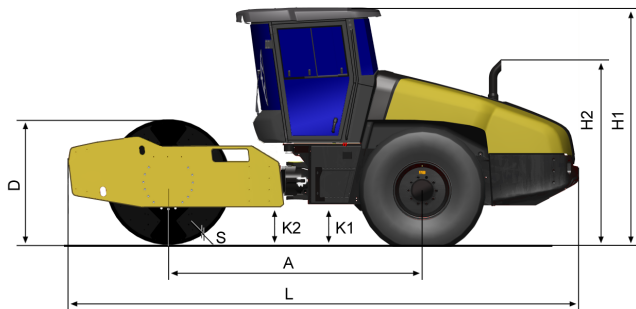

Dimensions

A. Wheelbase	118 in
B1. Width, front	91 in
B2. Width, rear	84 in
D. Drum diameter	60 in
H1. Height, with ROPS/cab	113 in
H2. Height, w/o ROPS/cab	84 in
K1. Ground clearance	18 in
K2. Curb clearance	18 in
L. Length	236 in
O1. Overhang, right	3 in
O2. Overhang, left	3 in
R1. Turning radius, outside	18 ft
R2. Turning radius, inside	11 ft
S. Drum shell thickness	1.38 in
W. Drum width	84 in
α . Steering angle	$\pm 38^\circ$



Standard equipment

- 24V outlet socket, operator's platform
- Automatic vibration control
- Back up alarm
- Brake release
- Cross Mounted Engine
- Combi cooler with Hydraulically driven fan
- Display: Engine temp, Fuel level, Hydr. temp, Speedometer, Tachometer, Voltage
- Dual speed drum and axle motors
- Emergency stop
- Filler cap inside lockable hood
- Hydraulic checkpoints
- Parking brake
- Shock mounted platform
- Steering wheel, adjustable
- Suspension seat, swivelling
- Storage Compartment
- Traction Control Package w/tilt indicator and speed limiter
- Vandal cover
- Warning lights: Air cleaner, Brake, Clogged hyd. fluid filter, Engine oil pressure/temp, Hyd oil temp, Low charge, Low fuel
- 1m X 1m Visibility
- Zero spill oil & coolant change

Find us locally at www.atlascopco.com

We reserve the right to change specifications without notice. Photos and illustrations do not always show standard versions of machines. The above information is a general description only, all informations are supplied without liability.

rce_ca3500d_us-20151207.160812.pdf 2015-12-07 16:08